

Single Acting, Pneumatic/Hydraulic Pump, FP

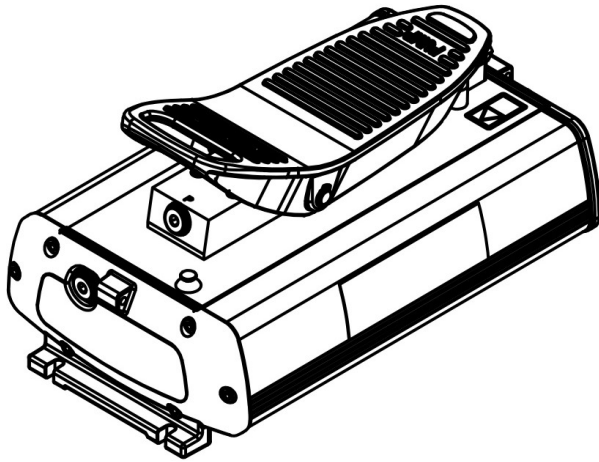

FP- Foot Pedal. The FP option is ideal when both hands of the operator needs to be working with the work piece or tool. The foot pedal control the start/stop of hydraulic flow and also its release back to the oil reservoir.

Technical Data:

Vibration Level:
2.5 < m/s²



No Limit

Air pressure	6.5 Bar
Operating Pressure	700 Bar
Oil Eff. Oil vol. cm ³	2500 cm ³
Cap. cm ³ /min high per min	260 cm ³
Cap. cm ³ /min low per min	1150 cm ³
Weight	10.1 kg

Working Pressure MPa	70 MPa
Dimensions mm	335 (A) x 187 (B) x 209 (C)

P Pressure Outlet	Air Inlet
G1/4"	G1/4"

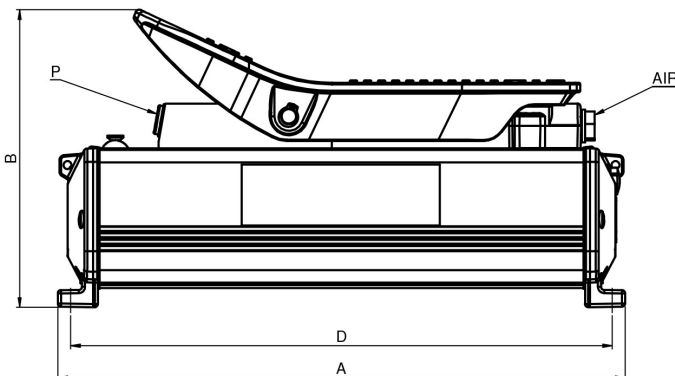
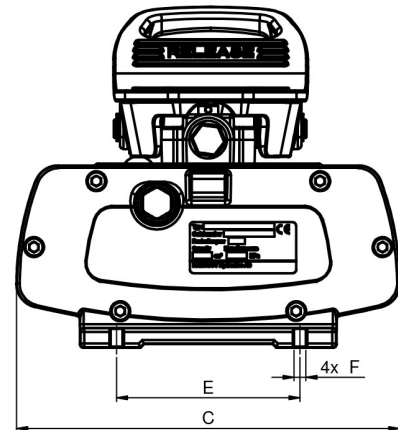

E mm	F mm
100	6.5

* The operating inlet pressure range is 1.2—6.5 bar.

We reserve the right to introduce changes to our product range and /or designs without prior notice